

**FORGED NEEDLE VALVE**  
**1/8" - 3/8" NPT**  
**1/8" and 1/4" Dual Ferrule Tube**  
**Vacuum - 5000 Psig (345 Bar)**

**FNV**

**SERIES**

**Description**

Series FNV Needle Valves feature a forged body, integral bonnet design with PTFE and metallic wafer stem packing. This provides leak-tite service from vacuum to the maximum operating pressure. Series FNV are available in Straight and Angle configurations, with NPT and Dual Ferrule Tube connections. The industry standard panel mounting allows the FNV to be a cost effective solution to many applications. Standard metal to metal stem and optional Soft Tip stem provide accurate metering over a wide range of pressures. The Series FNV can be ordered cleaned for Oxygen Service.

**Features**

- Metallic and PTFE Wafer Stem Packing provides low operating torque
- Panel Mounting Standard
- Metal to Metal Standard, Optional Soft Stem Tip (PCTFE)
- Straight or Angle Body Configurations
- Male and Female NPT or Dual Ferrule Tube Connections
- Suitable For Cryogenic Service
- 100% Factory Tested

**Technical Data**

Maximum Operating Pressure @ 100° F  
 Brass: 3000 Psig (207 Bar)  
 Stainless: 5000 Psig (345 Bar)

**Temperature/Pressure Ratings**

Temperature, °F (°C)	Max. Working Pressure, Psig (Bar)	
	Brass	316 SS
- 320 (-195) to 100 (37)	3000 (207)	5000 (345)
100 (37) to 250 (93)	2200 (151)	4085 (281)
250 (93) to 350 (176)	1470 (101)	3715 (255)
350 (176) to 400 (204)	-	3435 (236)

Temperature Range:

Metal to Metal Stem: -320° to 400° F (-195°C to 204°C)  
 PCTFE Soft Stem Tip: -20° to 200°F (-29° to 93°C)

Orifice: 0.17" (4.32 mm)

Stem Taper: 60 Degree

Flow Coefficient (Cv): 0.37

**Testing**

Every valve is factory tested with Nitrogen at 3000 Psig (207 Bar) for leakage. Maximum allowable seat leakage is 0.1cc/min.

**Materials of Construction**

Component	Brass	Stainless
Valve Body	Brass, ASTM 377	316 SS, ASTM A182
Packing Nut	Brass, ASTM B16	316 SS, ASTM A479
Regulating Stem	316 SS, ASTM A479	
Packing Washers	Brass, ASTM B36	316 SS, ASTM A479
Packing	PTFE, ASTM D1710	
Soft Stem Tip	PCTFE (Neoflon® M400), ASTM D1430	
Panel Nut	Brass, ASTM B16	303 SS, ASTM A582
Round Handle	Nylon 6/6 (Zytel®) with Brass Insert	
"T" Handle	303 SS, ASTM A582	
Handle Set Screw	304 SS, ASTM A182	
Lubricant	Oxygen Compatible Perfluoropolyether (PFPE) Grease	



# FORGED NEEDLE VALVE

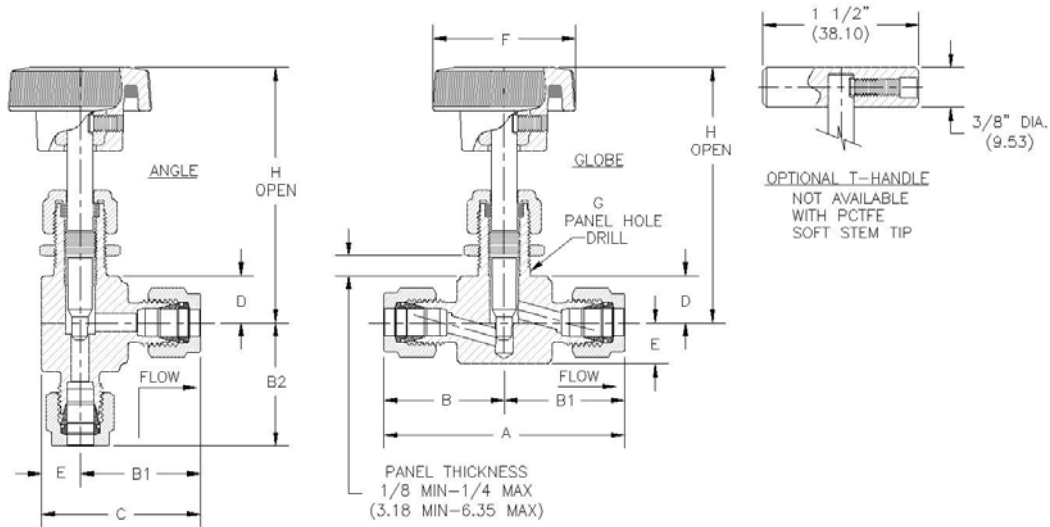

## Dimensional Data

MODEL CODE	PORT CONFIGURATION		Dimension in inches (mm)										
	INLET	OUTLET	A	B	B1	B2	C	D	E	F	G	H (open)	Orifice
FNV-2T	1/8" Tube		2.07 (52.58)	1.04 (26.42)	1.04 (26.42)	1.04 (26.42)	1.42 (36.07)	0.44 (11.18)	0.38 (9.65)	1.34 (34.04)	0.53 (13.46)	2.34 (59.44)	.08 (2.03)
FNV-2F	1/8" Female NPT		1.62 (41.15)	.81 (20.57)	.81 (20.57)	.81 (20.57)	1.19 (30.23)						
FNV-2M	1/8" Male NPT		1.70 (43.18)	.85 (21.59)	.85 (21.59)	.85 (21.59)	1.24 (31.50)						
FNV-2MF	1/8" Male NPT	1/8" Female NPT	1.67 (42.42)		.81 (20.57)	.81 (20.57)	1.19 (30.23)						
FNV-2MT	1/8" Male NPT	1/8" Tube	1.89 (48.01)		1.02 (25.91)	1.02 (25.91)	1.41 (35.81)						
FNV-2M4T	1/8" Male NPT	1/4" Tube	2.01 (51.05)		1.15 (29.21)	1.15 (29.21)	1.54 (39.12)						
FNV-4T	1/4" Tube		2.31 (58.67)		1.15 (29.21)	1.15 (29.21)	1.11 (28.19)						1.49 (37.85)
FNV-4F	1/4" Female NPT		2.12 (53.85)	1.06 (26.92)	1.06 (26.92)	1.02 (25.91)	1.40 (35.56)						
FNV-4M	1/4" Male NPT		2.04 (51.82)	1.02 (25.91)	1.02 (25.91)	1.02 (25.91)	1.51 (38.35)						
FNV-4MF	1/4" Male NPT	1/4" Female NPT	2.08 (52.83)		1.06 (26.92)	1.06 (26.92)	1.54 (39.12)						
FNV-4MT	1/4" Male NPT	1/4" Tube	2.17 (55.12)		1.12 (28.45)	1.12 (28.45)	1.51 (38.35)						
FNV-6M	3/8" Male NPT		2.25 (57.15)		1.12 (28.45)	1.12 (28.45)	1.51 (38.35)						

Note: Dimensions are shown with Bi-Lok nuts finger-tight. Dimensions are in inches (millimeters), for reference only and subject to change. All valve bodies are 3/4" (19 mm) wide. NPT Threads per ASME B1.20.1

## Flow Coefficient (Cv) @ Turns Open

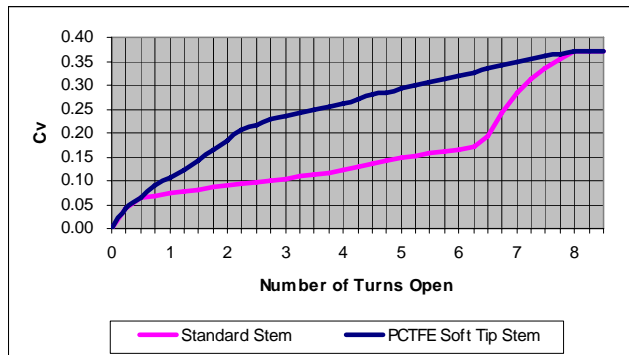

## How To Order

FNV-4TASS-K-X

- Model Code: FNV - Forged Needle Valve. See Dimensional Data Above.
- Body Configuration: For Angle Configuration, Add "A" to Model Code.
- Material Code: B - Brass, SS - 316 Stainless Steel.
- Options: K - PCTFE Soft Tip Stem, SH - Stainless Steel Handle.
- Cleaning Option: X - Cleaned and Packaged for Oxygen Service.

Neoflon® is a registered trademark of Daikin Industries of Japan. Zytel® is a registered trademark of DuPont.

PROPER COMPONENT SELECTION - When specifying a component, the total system design must be considered to ensure safe and trouble-free performance. Intended component function, materials compatibility, pressure ratings, installation, environment and maintenance are the responsibility of the system designer.



www.generant.com

1865 Route 23 South PO Box 768 Butler, New Jersey 07405 973.838.6500 Fax 973.838.4888